

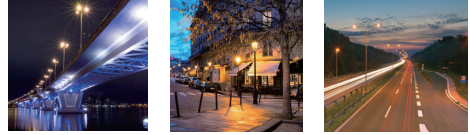

# STREAM 220 PUBLIC SERIES

KAP-STB-300



## Electrical / Electrique

Power / Puissance	220
Input voltage / Tension d'entrée	120 - 277 VAC
Input current / Courant d'entrée	3.1 A MAX
Frequency / Fréquences	50 - 60 Hz
Power factor / Facteur de puissance	> 0.9

## Lighting / Eclairage

Beam angle / Angle de faisceau	90°X120°
Efficiency / Efficacité	111 Lumens/w
Lumen output / Sortie lumens	24500 Lumens
CRI / IRC	> 80
Color temperature / Température de couleur	3000 - 3500 K 4000 - 4500 K 4800 - 5100 K 5200 - 5700 K

## Components & fixture / Composants et structure

Body material / Matériau du corps du projecteur	Aluminum / Aluminium
Product painting color / Couleur de la peinture	Silver grey / Gris argenté
Screws material / Matériau des visseries	Stainless steel316 / Acier inoxydable316
Cover material / Matériau du couvercle	PC lens / Lentilles en Polycarbonate
Cable specifications / Spécifications du cable	HO5RNF (3G1.0mm <sup>2</sup> )
LED Chipset / Puces LED	Lumileds Luxeon 3030
Cable length / Longueur du cable	0.5m / 1.0m

## Temperatures / Températures

Storage temperature / <i>Température de stockage</i>	-20°C ~ +40°C
Operating temperature / <i>Température d'utilisation</i>	-20°C ~ +40°C
Storage Humidity / <i>Humidité de storage</i>	10% - 90%

## Additional product data / Informations supplémentaires

Lifetime / <i>Durée de vie</i>	> 50.000 Hours
Warranty / <i>Garantie</i>	5 years / 5 ans
International Standards / <i>Normes internationales</i>	Eco-Design(ERP)



## Model number / Numéro de référence

Example for STREAM 220 with silver painting / color temperature 4000K / 0.5m cable  
*Exemple pour STREAM 220 avec peinture argentée / couleur de température 4000k / cable 0.5m*

**KAP -STB -220 -S 4 -C05**

STREAM series with Lumileds LED chipsets  
*Gamme STREAM avec puces LED Lumileds*

Power / *Puissance* : **220w**

Product painting color / *Couleur de la peinture*  
**Silver grey (Gris argenté)**

Cable length / *Longueur du cable* :  
**0.5m / 1.0m**

Color temperature / *Température de couleur*  
**3**(3000-3500K)  
**4**(4000-4500K)  
**5**(4800-5100K)  
**6**(5200-5700K)

## Product Dimensions

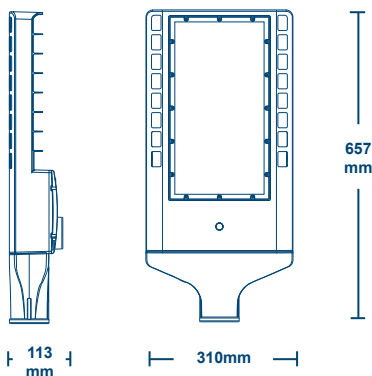

## Photometry / Photométrie

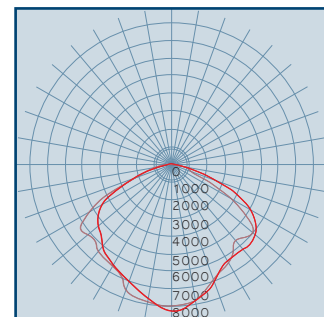

## Packing Information / Information Colisage

Packing details	Size (mm)	Qty / ctn(pcs)	Net Weight (kg)	Gross Weight (kg)
Product	657.7*310*112.3	/	11	/
Inner box	/	/	/	/
Master Carton	670*320*130	1	/	11.5